

— PROPRIETARY —  
 THIS DOCUMENT CONTAINS CONFIDENTIAL, PROPRIETARY INFORMATION  
 THAT IS FOX PROPERTY. DO NOT DISCLOSE TO OR DUPLICATE  
 FOR OTHERS EXCEPT AS AUTHORIZED BY FOX.

REVISIONS				
ZONE	REV	DESCRIPTION	DATE	APPROVED
	A	PRODUCTION RELEASE	2/8/18	CR

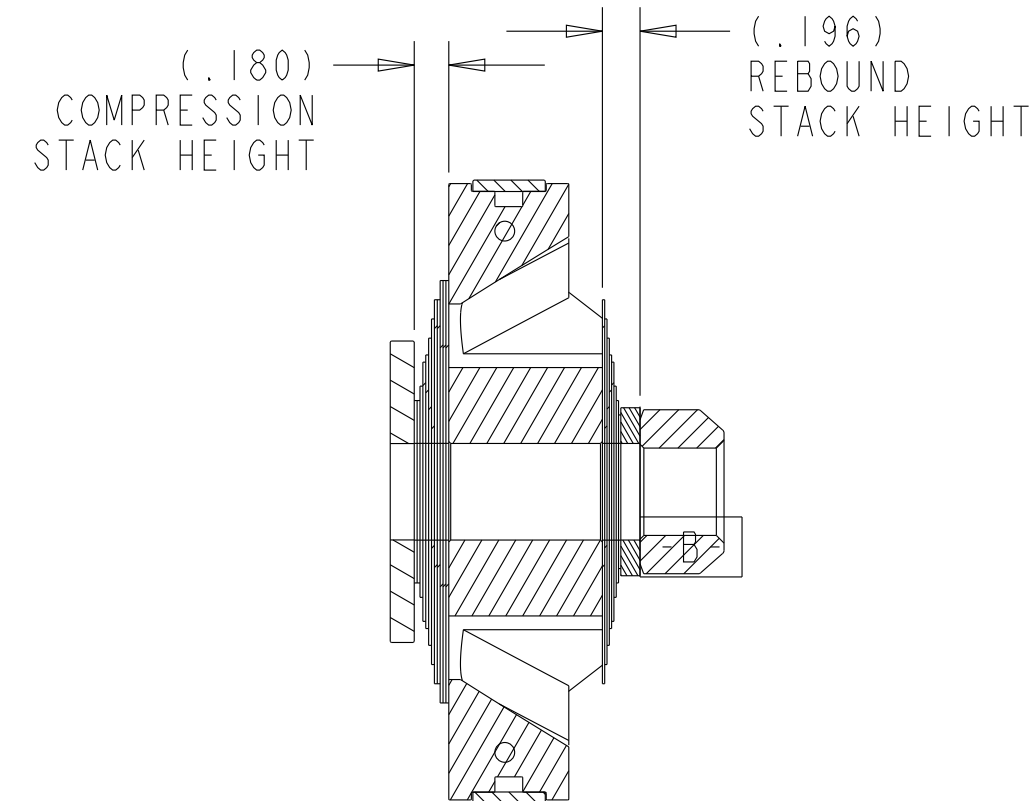
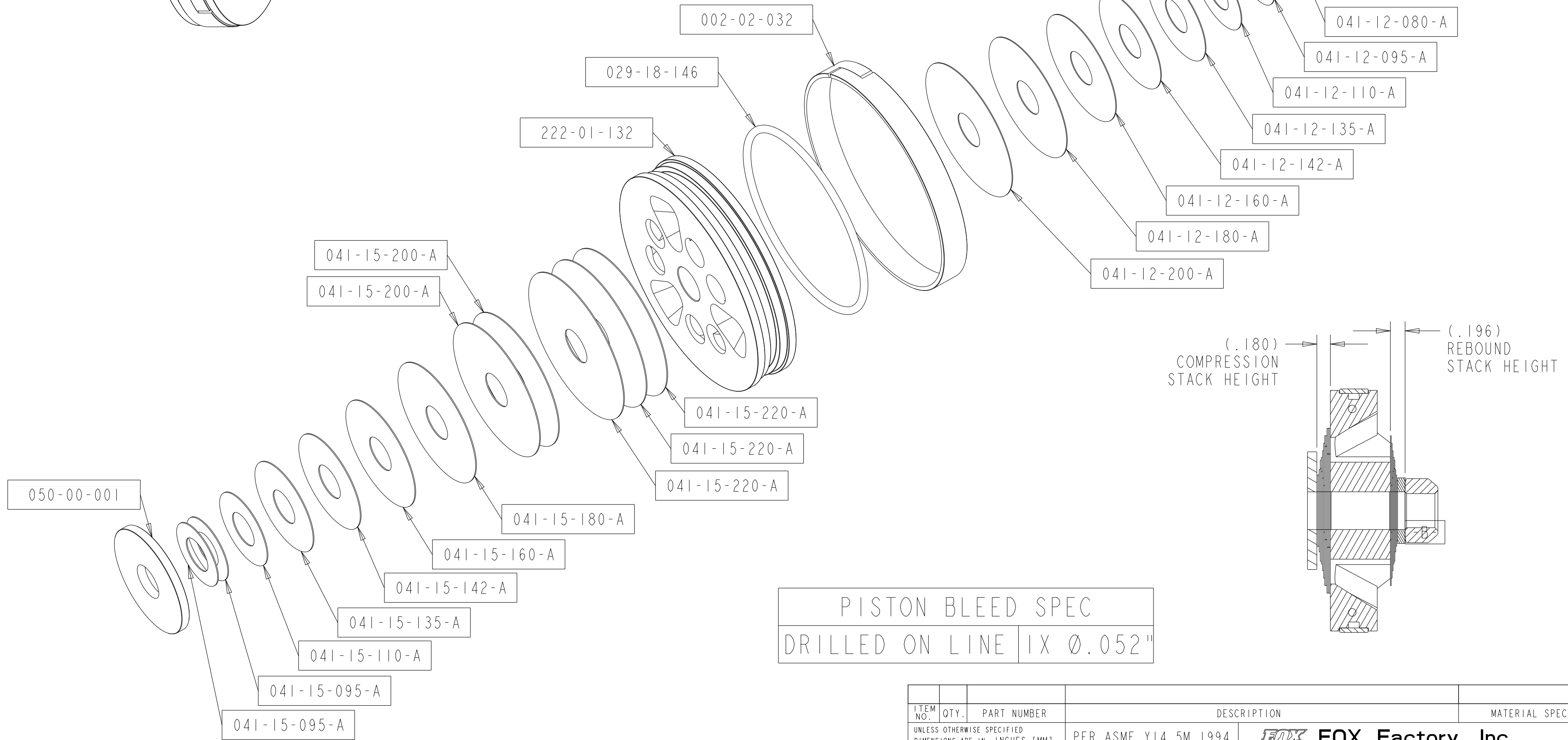
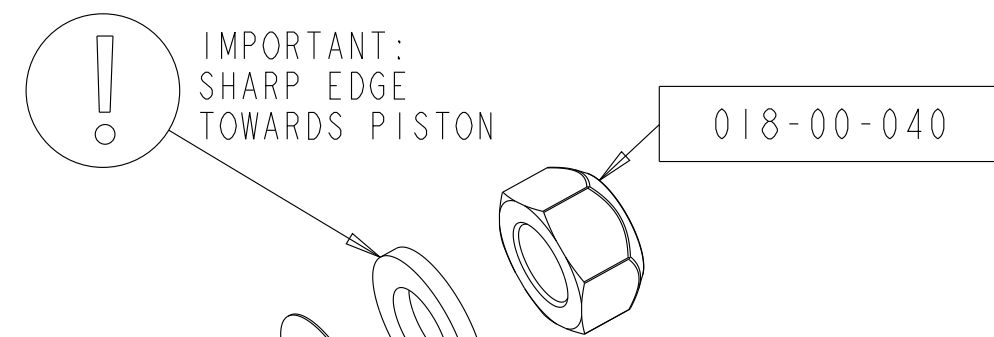
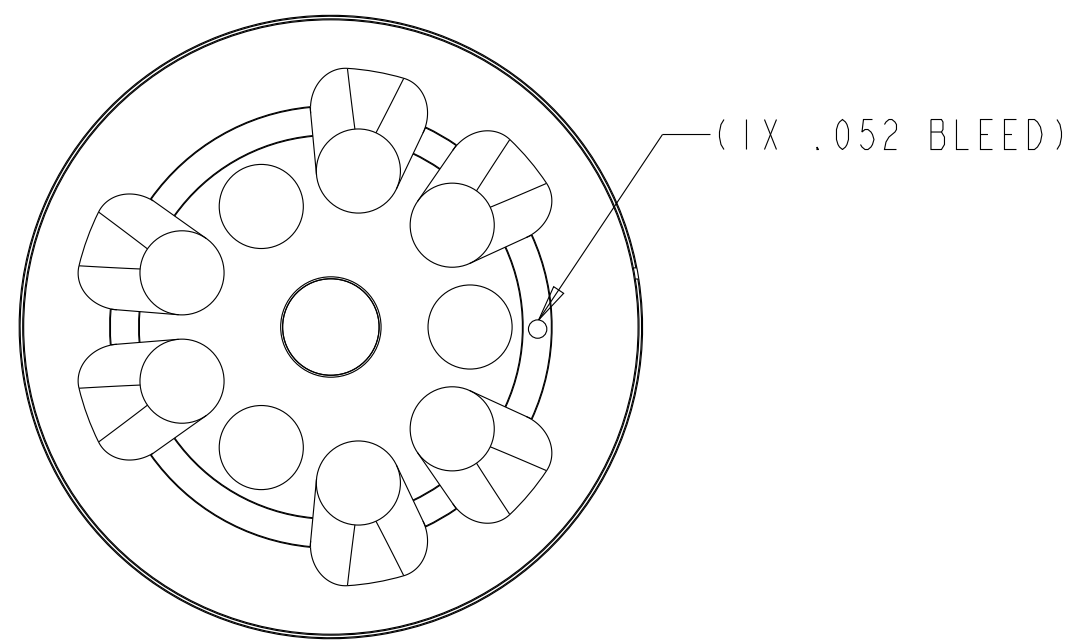
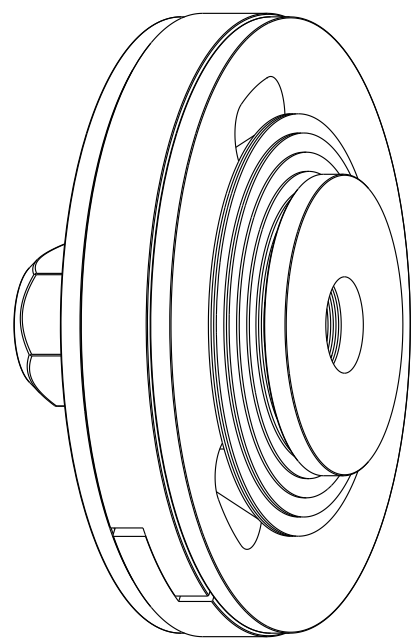

PISTON BLEED SPEC  
 DRILLED ON LINE 1X Ø.052"

- NOTES:  
 1. REFERENCE: 3,2/70 (1X .052 BLEED)  
 2. FIRST APPLICATION: 3.5 SERIES BYPASS

ITEM NO.	QTY.	PART NUMBER	DESCRIPTION	MATERIAL SPEC
UNLESS OTHERWISE SPECIFIED DIMENSIONS ARE IN INCHES [MM]		PER ASME Y14.5M 1994		<b>FOX Factory, Inc.</b> 130 Hangar Way, Watsonville, CA 95076 USA, Ph 831-768-1100, Fax 831-768-9312
TOLERANCES ARE:		APPROVALS	DATE	
DECIMALS	.XX (.X) ± .01 [0.25]	DWN. BY	M. SHELTON	2/8/18
ANGLES	± 1°	CHK. BY		
.XXX [.XX] ± .005 [0.13]		ENG.	C. RAHDEES	2/8/18
THIRD ANGLE PROJECTION		MFG.		
		ADD.		
			SIZE	PART NO.
			C	807-24-701
PLOT SCALE 1.00:1				SHEET 1 OF 2







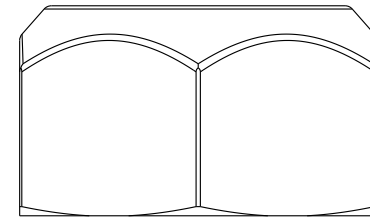

4

3

2

1



-  BACK UP WASHER
-  0.800 X .012
-  0.950 X .012
-  1.100 X .012
-  1.350 X .012
-  1.420 X .012
-  1.600 X .012
-  1.800 X .012
-  2.000 X .012

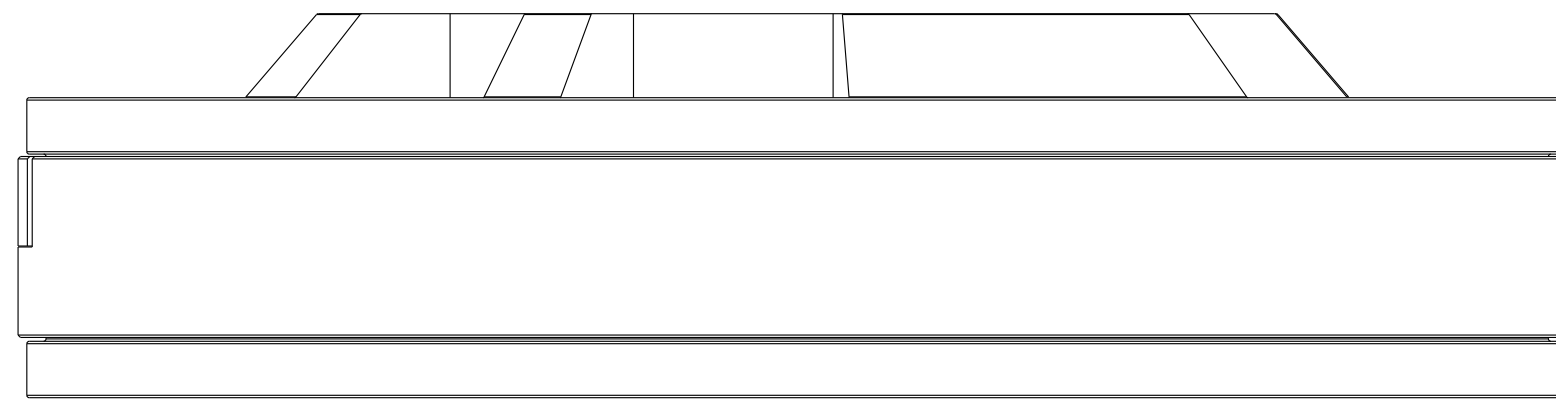

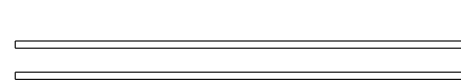
-  (3X) 2.200 X .015
-  (2X) 2.000 X .015
-  1.800 X .015
-  1.600 X .015
-  1.420 X .015
-  1.350 X .015
-  1.100 X .015
-  (2X) 0.950 X .015

-  TOP OUT WASHER

D

D

C

C

B

B

A

A

— PROPRIETARY —  
 THIS DOCUMENT CONTAINS CONFIDENTIAL, PROPRIETARY INFORMATION  
 THAT IS FOX PROPERTY. DO NOT DISCLOSE OR DUPLICATE  
 FOR OTHERS EXCEPT AS AUTHORIZED BY FOX

SIZE C	CAGE NO. NONE	DWG. NO. 807-24-701	REV. 1
PLOT SCALE 1.000		INCHES	SHEET 2 OF 2

4

3

2

1