

— PROPRIETARY —
 THIS DOCUMENT CONTAINS CONFIDENTIAL, PROPRIETARY INFORMATION THAT IS FOX PROPERTY. DO NOT DISCLOSE TO OR DUPLICATE FOR OTHERS EXCEPT AS AUTHORIZED BY FOX.

REVISIONS				
ZONE	REV	DESCRIPTION	DATE	APPROVED
	A	RELEASE TO PRODUCTION	10-31-16	BS
	B	CHANGED PISTON PN AND WEAR BAND, ADD O-RING	05-22-19	BS
1C	C	CHANGED PISTON NUT TO 018-00-075	06-09-20	CR
3B 3C 3C 3C 3C	D	PISTON WAS: 222-01-484 IS: 222-01-484 WEAR BAND WAS: 002-00-000 IS: 002-02-054 O-RING WAS: 029-11-029 IS: 029-18-029 REMOVED ALL 041-15-160-A SHIMS, ADDED ONE 041-15-135-A SHIM TO COMP SIDE	02-18-23	NL/BS
3C	E	O-RING WAS: 029-18-029 IS: 029-11-029 WEARBAND WAS: 002-02-054 IS: 002-50-020	06-01-23	NL/BS

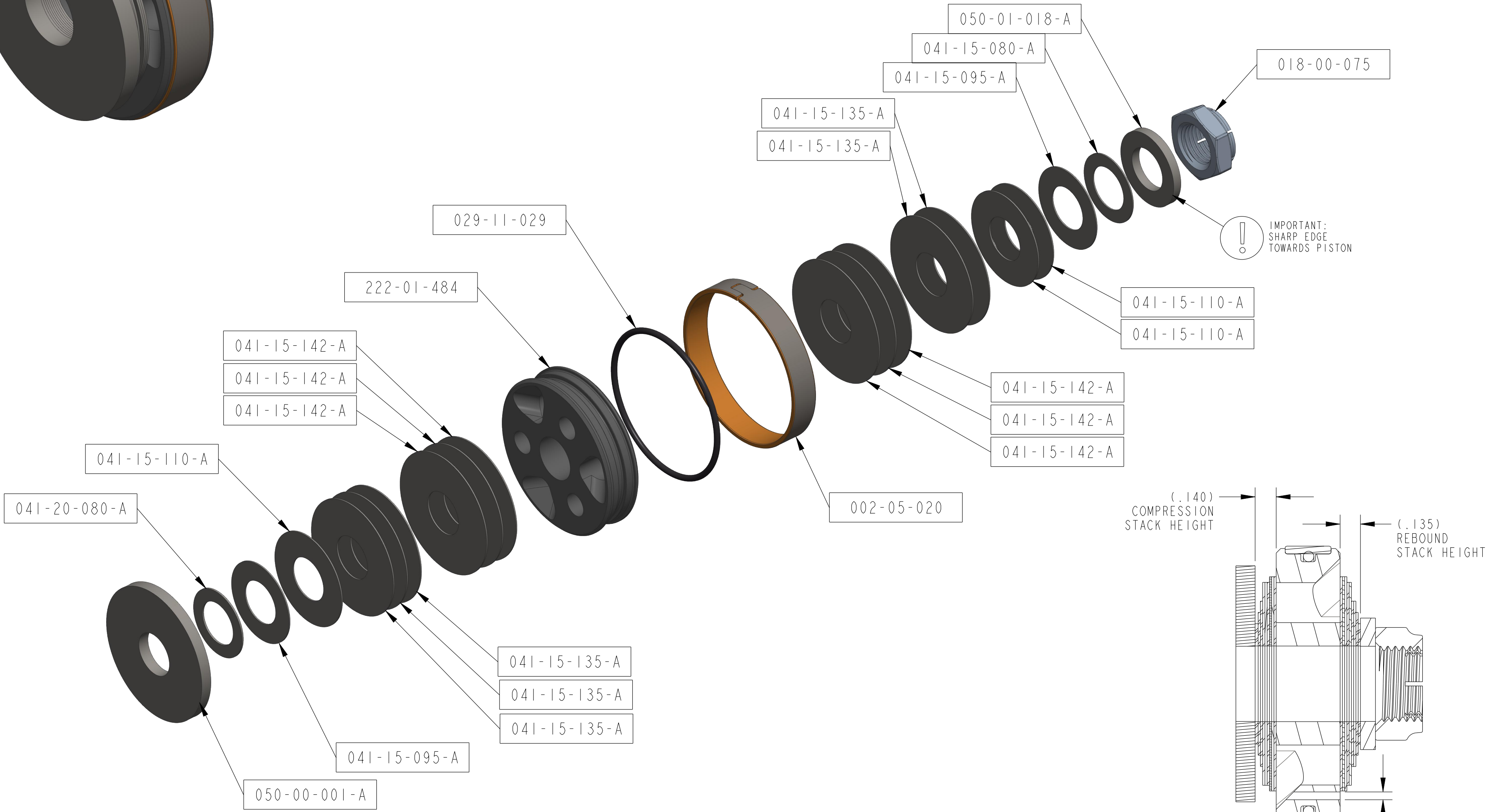

IMPORTANT:
 SHARP EDGE
 TOWARDS PISTON

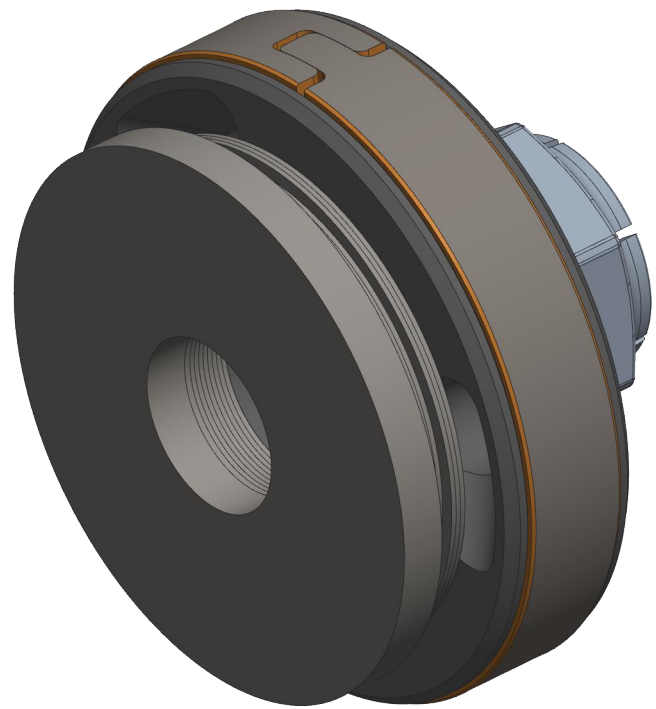
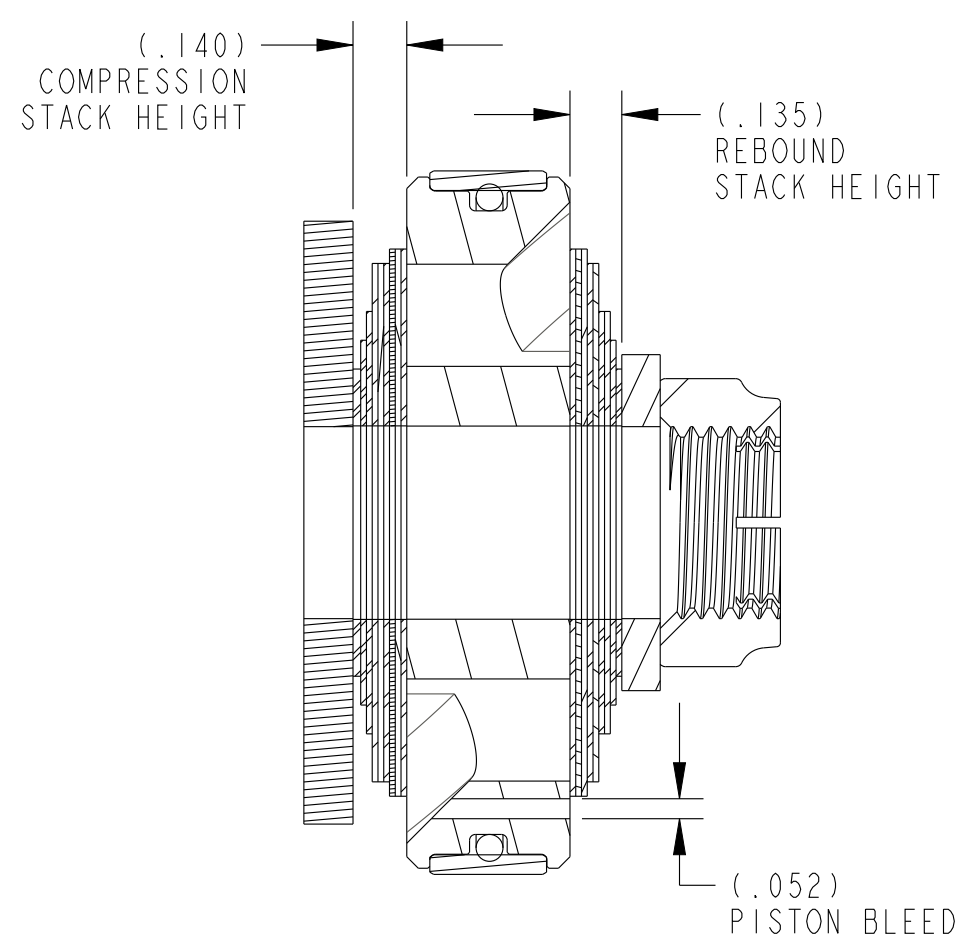

NOTES:
 1. APPLICATION: 2.0 FRS BUMPSTOP

UNLESS OTHERWISE SPECIFIED DIMENSIONS ARE IN: INCHES [MM]		PER ASME Y14.5-2018		FOX FACTORY, INC.	
DEV PROJECT #:		APPROVALS		TITLE	
TOLERANCES ARE:		DWN. BY B SMITH		VALVING ASSEMBLY:	
DECIMALS	ANGLES	DATE 10-31-16		2.0 FACTORY RACE SERIES	
.XX [.X] ±.01 [0.25]	± 1°	CHK. BY		TUNED COMBINATION 007	
.XXX [.XX] ±.005 [0.13]		ENG. B SMITH		SIZE	DWG. NO.
THIRD ANGLE PROJECTION		MFG.		C	807-24-007
		QC.		PLOT SCALE: 2.00	
				SHEET: 1 OF 2	

4

3

2

1

D

D

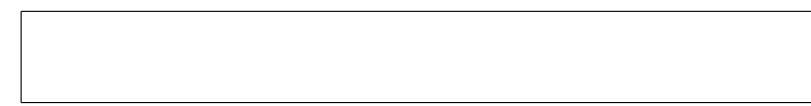
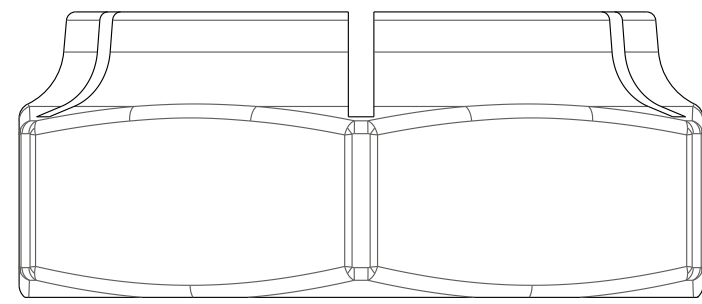

BACK UP WASHER



0.800 X .015

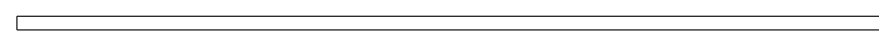

0.950 X .015

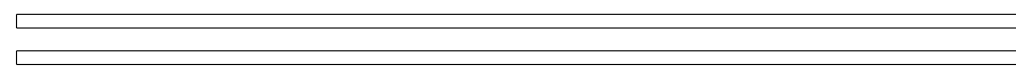

(2X) 1.100 X .015

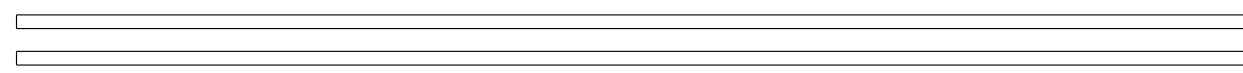

(2X) 1.350 X .015

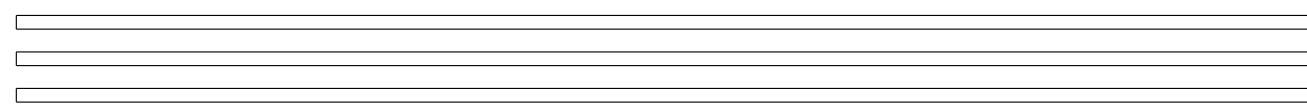

(3X) 1.425 X .015

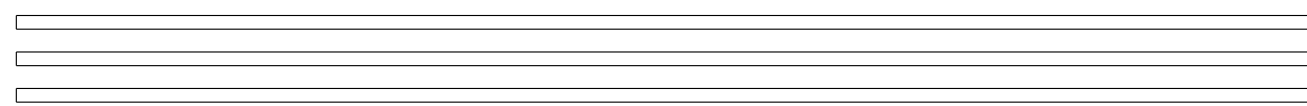
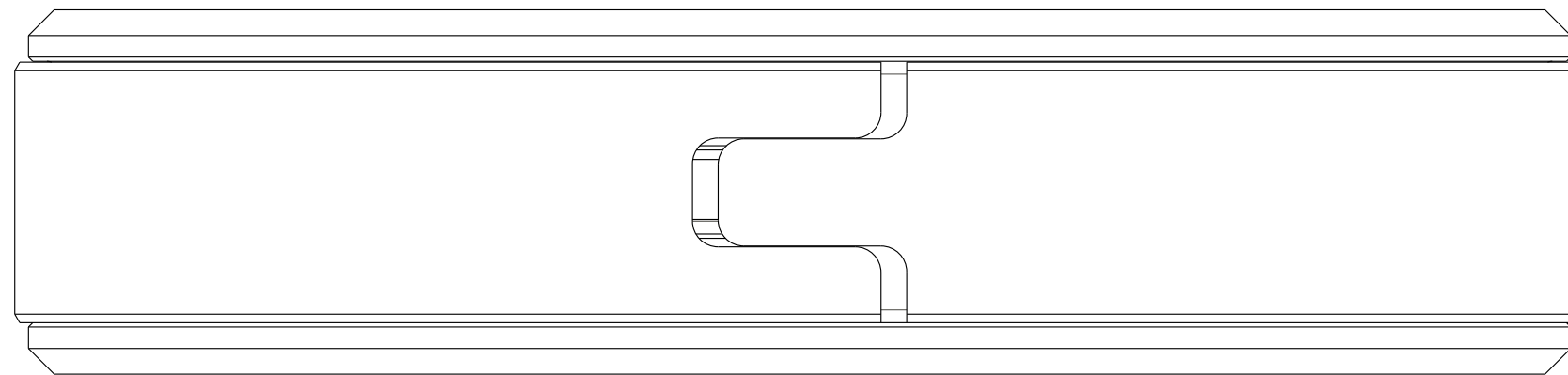

(3X) 1.425 X .015

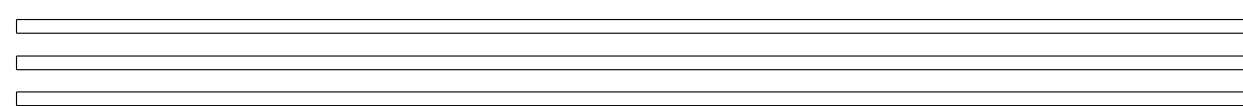

(3X) 1.350 X .015

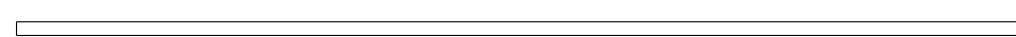

1.100 X .015

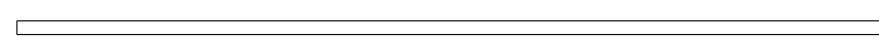

0.950 X .015



0.800 X .020



TOP OUT WASHER

C

C

B

B

A

A

- PROPRIETARY -
 THIS DOCUMENT CONTAINS CONFIDENTIAL, PROPRIETARY INFORMATION
 THAT IS FOX PROPERTY. DO NOT DISCLOSE TO OR DUPLICATE
 FOR OTHERS EXCEPT AS AUTHORIZED BY FOX.

SIZE	DWG. NO.	REV.
C	807-24-007	B
PLOT SCALE 1.50:1 SHEET		2 OF 2

4

3

2

1