

E4-WM5-Y631A00

MOUNTING INSTRUCTION



This instruction is for both left front (driver) 25-287806 and right front (passenger) 25-287813 B8 8100 shocks. A bill of materials (BOM) of the included mounting parts kits is shown on the next page.

IMPORTANT! READ THIS FIRST!

Installation of shock absorbers requires special tools and expert knowledge. Accordingly, installation of all BILSTEIN products must be performed by a qualified suspension specialist.

When replacing other brands, BILSTEIN shock absorbers should always be installed as a set. All BILSTEIN products must only be used for the specific, intended application as indicated in the application guide. **Any use of any BILSTEIN product other than for its intended use may result in serious bodily injury or death.**

Always use a chassis hoist for the installation of BILSTEIN products and make certain that the raised vehicle is securely attached to the hoist and/or supported to prevent the vehicle from slipping, falling, or moving during the installation process.

If you choose to install any BILSTEIN product without the necessary special tools, expertise or chassis hoist, you may subject yourself to the risk of serious bodily injury or death. If you elect not to use a chassis hoist, at least make sure the vehicle is on level ground, that all tires on the ground during installation are blocked to prevent movement, that at least two tires are on the ground at all times, and that adequately secured safety stands (jack stands) are used to support the chassis. **NEVER** get under the vehicle until you have checked to make sure all of these steps are performed.

BILSTEIN suspension products are gas-filled and are highly pressurized.

- Never place any BILSTEIN product in a vise or use a clamp on any BILSTEIN product.
- Never apply heat near any BILSTEIN product.
- Never attempt to open or repair any BILSTEIN product, in order to prevent **serious bodily injury or death.**

Any attempt to misuse, misapply, modify, or tamper with any BILSTEIN suspension product voids any warranty and **may result in serious bodily injury or death.**

While installing any BILSTEIN product:

- Do not use impact tools for loosening or tightening fasteners, because this may destroy the screw threads.
- Self-locking fasteners must only be used **once!**
- Reuse original equipment components only if they are in good condition, otherwise replace them with new components.
- Never remove the slight film of oil on the piston rod and seal.
- All mounting fasteners for shocks and struts must be securely tightened before the vehicle is operated.

After installing any BILSTEIN product:

- The suspension caster and camber must be checked and/or adjusted to comply with the vehicle manufacturer's specifications.
- The (load dependent) brake compensator and the anti-lock brake system must be checked and/or reset to comply with the vehicle manufacturer's specifications.
- The headlight aim must be checked and adjusted.

B8 8100 bypass shocks feature a proprietary BILSTEIN zinc plated finish. This finish must be serviced in order to maintain its luster. Particularly in moist climates, a protective coating, such as a wax or lubricating oil should be periodically applied to prevent tarnishing. This finish is not covered under warranty.

It is normal to hear a slight audible clicking noise during compression and rebound strokes in the B8 8100 bypass shocks, most notably during low velocity events. This is due to the internal check pistons opening and closing to create the externally adjustable compression and rebound zones.

E4-WM5-Y631A00 MOUNTING INSTRUCTION

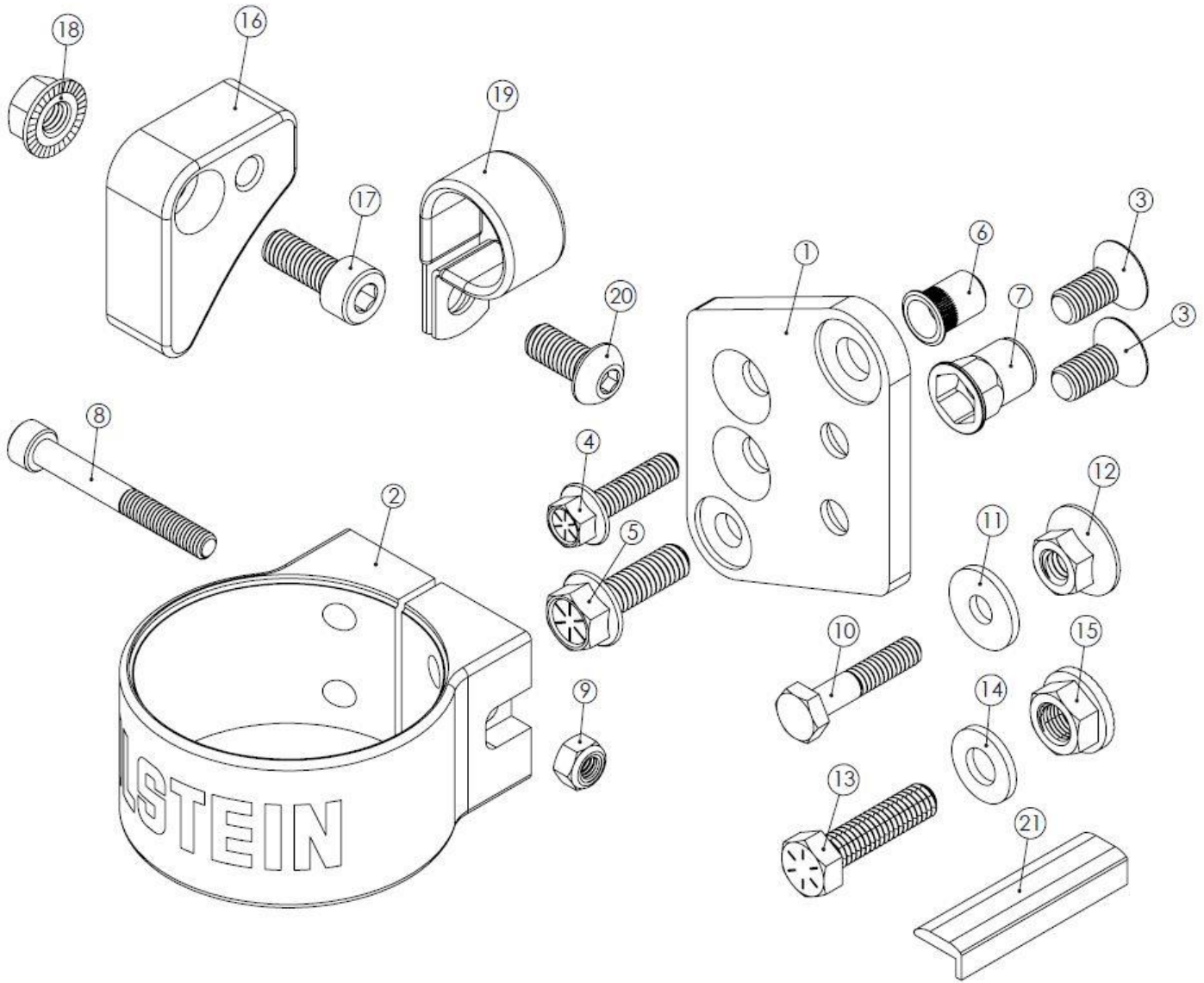

Figure 1 – Reservoir Mount Kit for Vehicle Left Side (25-287806)

E4-WM5-Y631A00 MOUNTING INSTRUCTION

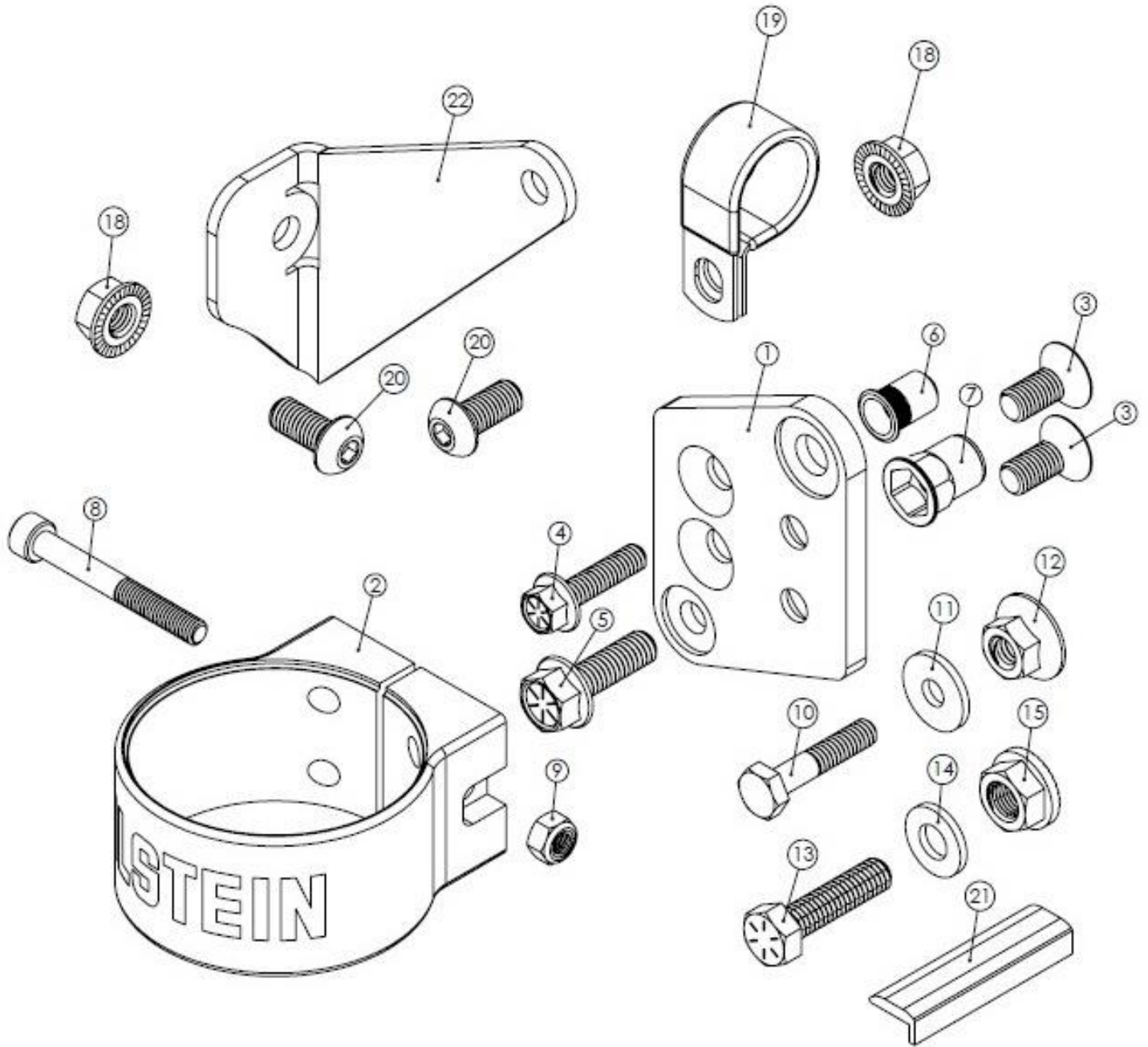

Figure 2 – Reservoir Mount Kit for Vehicle Right Side (25-287813)

E4-WM5-Y631A00

MOUNTING INSTRUCTION



Bill of Materials			
Item #	Description	Qty. in 25-287806	Qty. in 25-287813
1	Reservoir Bracket Plate	1	1
2	Reservoir Clamp; Ø60mm	1	1
3	Flat Head Screw; M8x1.25; L=18	2	2
4	Flange Head Cap Screw, 1/4"-20 x 1"	1	1
5	Flange Head Cap Screw, 5/16"-18 x 1"	1	1
6	Threaded Insert, 1/4"-20 Internal Thread	1	1
7	Threaded Insert, 5/16"-18, Internal, Hex	1	1
8	Socket Head Cap Screw; M6x1; L=50	1	1
9	Nylock; M6x1	1	1
10	Hex Head Cap Screw, 1/4"-20 x 1.25"	1	1
11	Washer, 1/4" ID x 3/4" OD, Grade 9 Steel	1	1
12	Serrated Flange Nut, 5/16"-18	1	1
13	Hex Head Cap Screw, 5/16"-18 x 1.25"	1	1
14	Washer, 5/16"	1	1
15	Serrated Flange Nut, 3/8"-24	1	1
16	Mount Bracket, Reservoir Hose, JL, Left	1	-
17	Socket Head Cap Screw, SS, M8x1.25, L=20	1	-
18	Serrated Flange Nut; M8x1.25	1	2
19	Loop Clamp, Hose, 7/8" Dia.	1	1
20	Button Head Screw; M8x1.25; L=18; SS	1	2
21	Rubber Strip	1	1
22	Mount Bracket, Reservoir Hose, JL, Right	-	1



B8 8100 bypass shock installation procedure:

B8 8100 bypass shocks are corner specific. The step by step procedure is shown with pictures of both sides. See page 22 for the end result.

Installation of B8 8100 bypass shocks requires the use of wheels with a maximum of 4.5" backspacing to ensure clearance between the tire and the shocks.

- A. Remove the existing shocks from the vehicle following all procedures in the vehicle manufacture's service manual. Inspect the OE upper bolts/washers for any excessive wear. If damage or excessive wear is present in any of these components, purchase the required replacement OE components.
- B. A mount kit is included to allow the remote reservoir to be attached to the vehicle frame rail behind the front bumper. This kit is depicted in Figure 1 for the left side shock (25-287806) and Figure 2 for the right side shock (25-287813).
- C. If you have access to a threaded insert gun or pliers, that may be preferable to set the provided threaded inserts (BOM item #6 & #7). Otherwise, using the items in Figure 3, and a 1/2" box end wrench, arrange them as shown and turn the 1/4"-20 screw (BOM item #10) by hand until it is snug as shown in Figure 4.

Note that the screw will pass through the serrated flange nut without engaging the threads. The serrations on the flange nut prevent the threaded insert from rotating while setting it.

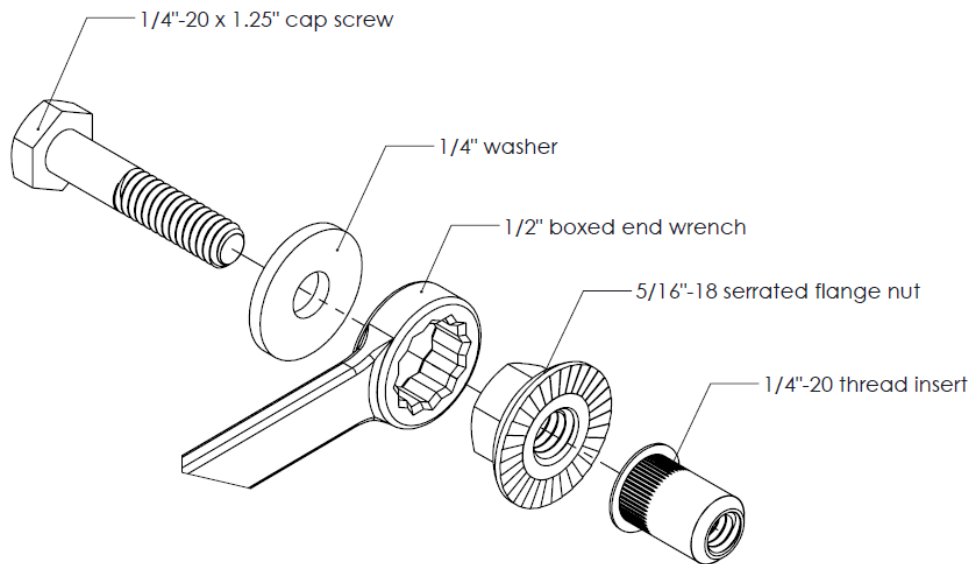

Figure 3

E4-WM5-Y631A00 MOUNTING INSTRUCTION

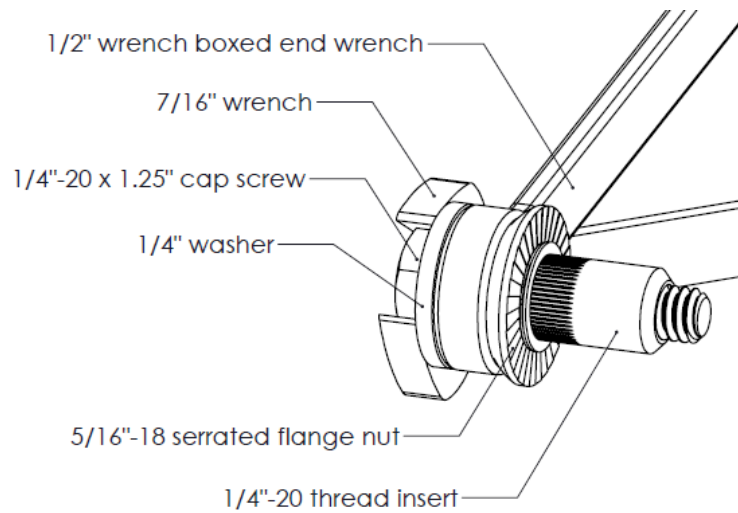

Figure 4

- D. For the left side, insert the threaded insert (BOM item #6) into the hole shown in Figure 5. For the right side, insert the threaded insert (BOM item #6) into the hole shown in Figure 6.



Figure 5 – Vehicle Left Side

1/4"-20
THREADED
INSERT

5/16"-18
HEX
INSERT



Figure 6 – Vehicle Right Side

- E. While keeping the threaded insert (BOM item #6) flange firm and parallel against the bumper support, tighten the screw (BOM item #10) using a 7/16" box end wrench or socket. Turn it 2 rotations to set the threaded insert. Tightening in 1/4 turn increments tends to work well.
- F. Remove and discard the screw (BOM item #10), washer (BOM item #11), and serrated flange nut (BOM item #12). The threaded insert (BOM item #6) should now be rigidly fixed in the hole.
- G. Assemble the 5/16"-18 hex screw (BOM item #13), 5/16" flat washer (BOM item #14), a 9/16" boxed end wrench, the 3/8" serrated flange nut (BOM item #15) and hex threaded insert (BOM item #7) the same way shown in Figure 3.

E4-WM5-Y631A00

MOUNTING INSTRUCTION



- H. For the left side, insert the hex threaded insert (BOM item #7) into the hole shown in Figure 5. For the right side, insert the hex threaded insert (BOM item #7) into the hole shown in Figure 6.
- I. While keeping the hex threaded insert (BOM item #7) flange firm and parallel against the bumper support, tighten the screw (BOM item #13) using a 1/2" box end wrench or socket. Turn it 2 rotations to set the hex threaded insert (BOM item #7). Tightening in 1/4 turn increments tends to work well.
- J. Remove and discard the screw (BOM item #13), washer (BOM item #14), and serrated flange nut (BOM item #15). The hex threaded insert (BOM item #7) should now be rigidly fixed in the hole.
- K. Prepare the reservoir mount assembly by applying non-permanent thread locker to two Flat Head Screws (BOM item #3). Mount the Reservoir Clamp (BOM item #2) to the Bracket Plate (BOM item #1) using the two Flat Head Screws (BOM item #3) as shown in Figures 7 and 8. Tighten the Flat Head Screws (BOM item #3) using a 5mm hex.

Torque both screws to 16 ft-lb (22 Nm).

- L. Place the Nylock (BOM item #9) in the slot of the Reservoir Clamp (BOM item #2) as shown in Figures 7 and 8. Then insert the Socket Head Cap Screw (BOM item #8) into the hole in the Reservoir Clamp (BOM item #2), threading it into the Nylock (BOM item #9) as shown in Figures 7 and 8. Using a 5mm Hex, Tighten the Socket Head Cap Screw (BOM item #8) only a few turns, leaving it loose enough so the reservoir can be installed a following step of these instructions.

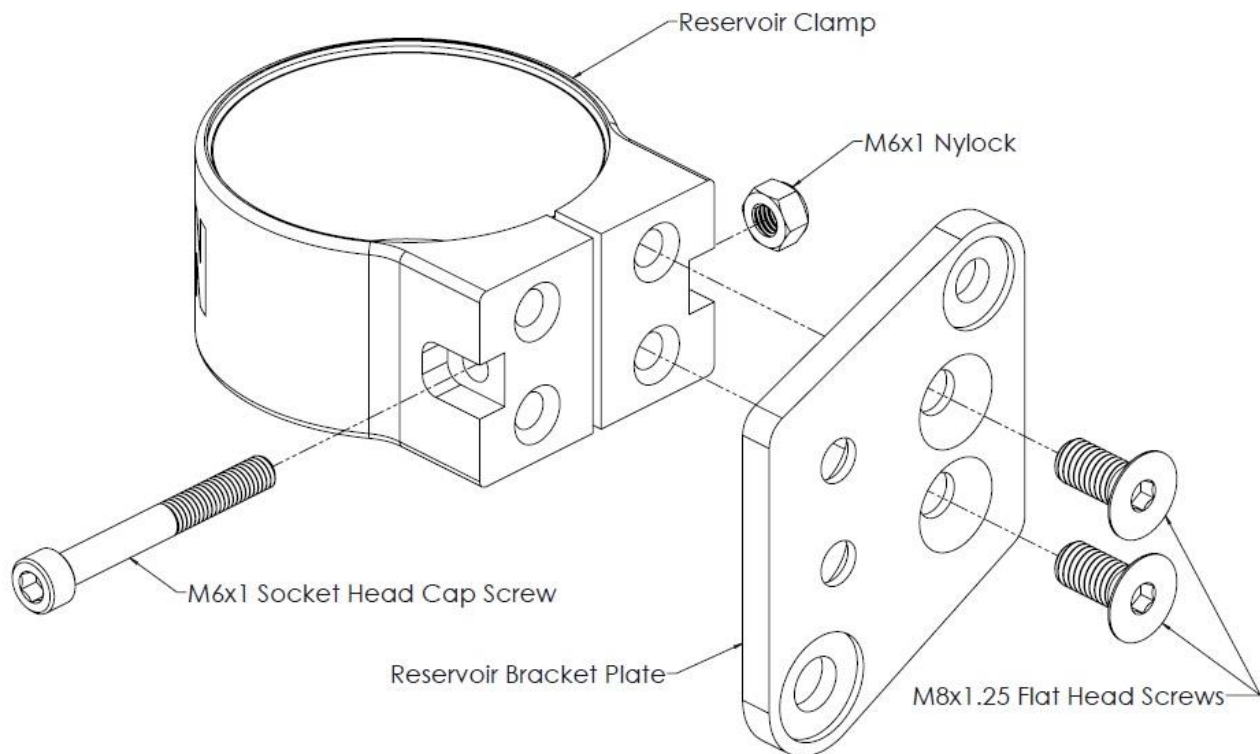

Figures 7 - Vehicle Left Side Assembly

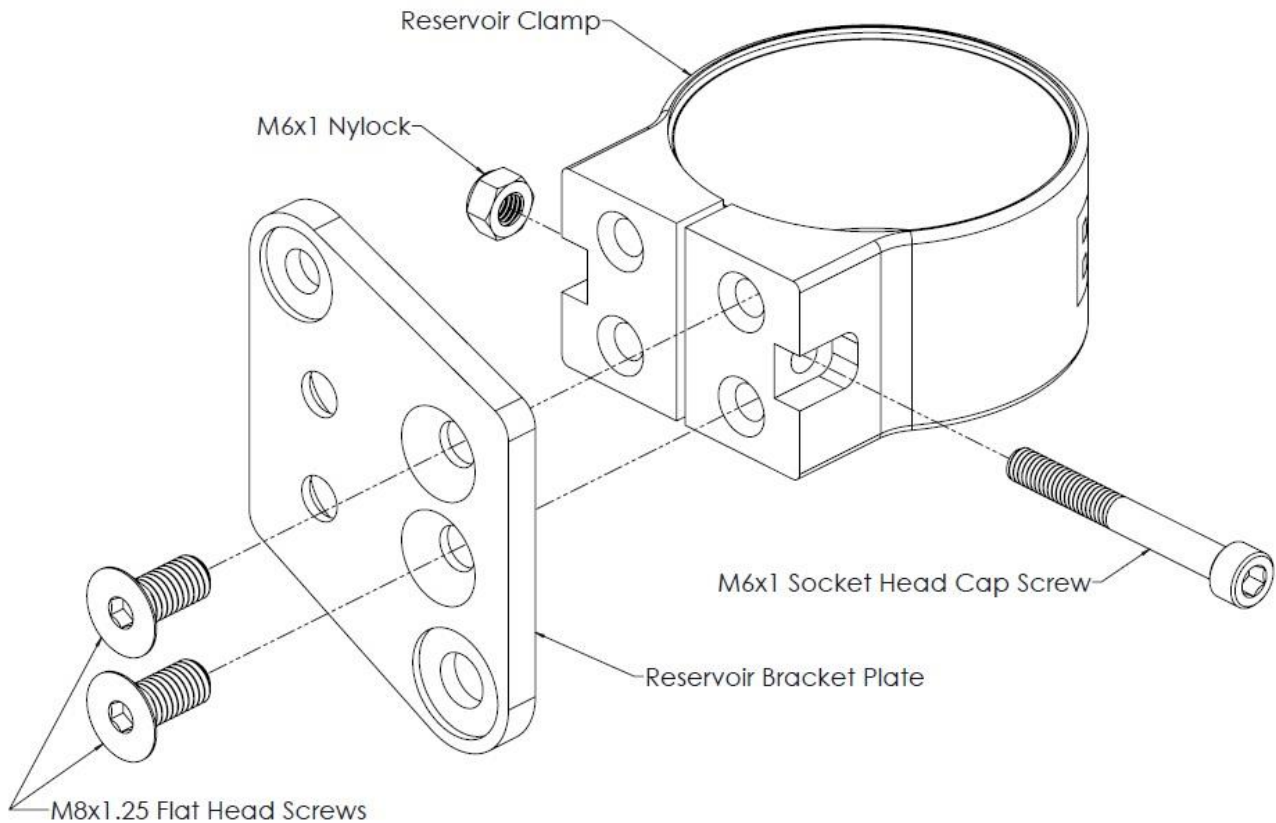

Figures 8 - Vehicle Right Side Assembly

Left Side Reservoir Hose Mount Bracket

- M. Locate the hole in the front side of the left spring bucket shown in figure 9. Using a M8x1.25 Socket Head Cap Screw (BOM item #17), and a M8x1.25 Serrated Flange Nut (BOM item #18), attach the Left Reservoir Hose Mount Bracket (BOM item #16) to the spring bucket and orient as shown in figures 10 and 11.

Torque the screw to 16 ft-lb (22 Nm).

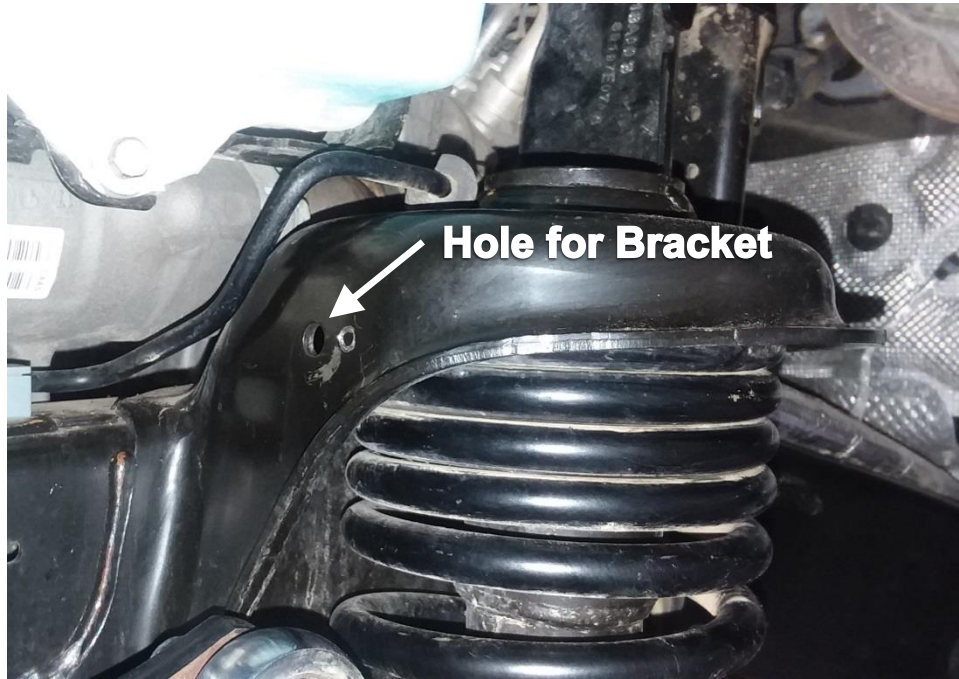

Figure 9 – Vehicle Left Side Spring Bucket



Figure 10 – Vehicle Left Side Reservoir Hose Mount Bracket



Figure 11 – Vehicle Left Side Serrated Flange Nut Installed

Right Side Reservoir Hose Mount Bracket

- N. Locate the hole in the front side of the right spring bucket shown in figure 12. Using a M8x1.25 Button Head Screw (BOM item #20), and a M8x1.25 Serrated Flange Nut (BOM item #18), attach the Right Reservoir Hose Mount Bracket (BOM item #22) to the spring bucket and orient as shown in figures 13 and 14.

Torque the screw to 16 ft-lb (22 Nm).



Figure 12 – Vehicle Right Side Spring Bucket



Figure 13 – Vehicle Right Side Hose Bracket



Figure 14 – Vehicle Right Side Serrated Flange Nut Installed

Shock Upper Mount Installation

- O. Install the shock's upper mount using the supplied 30mm Spacer, and OE upper bolt/washer as shown in Figures 15 through 18. Do not tighten at this time.

E4-WM5-Y631A00 MOUNTING INSTRUCTION

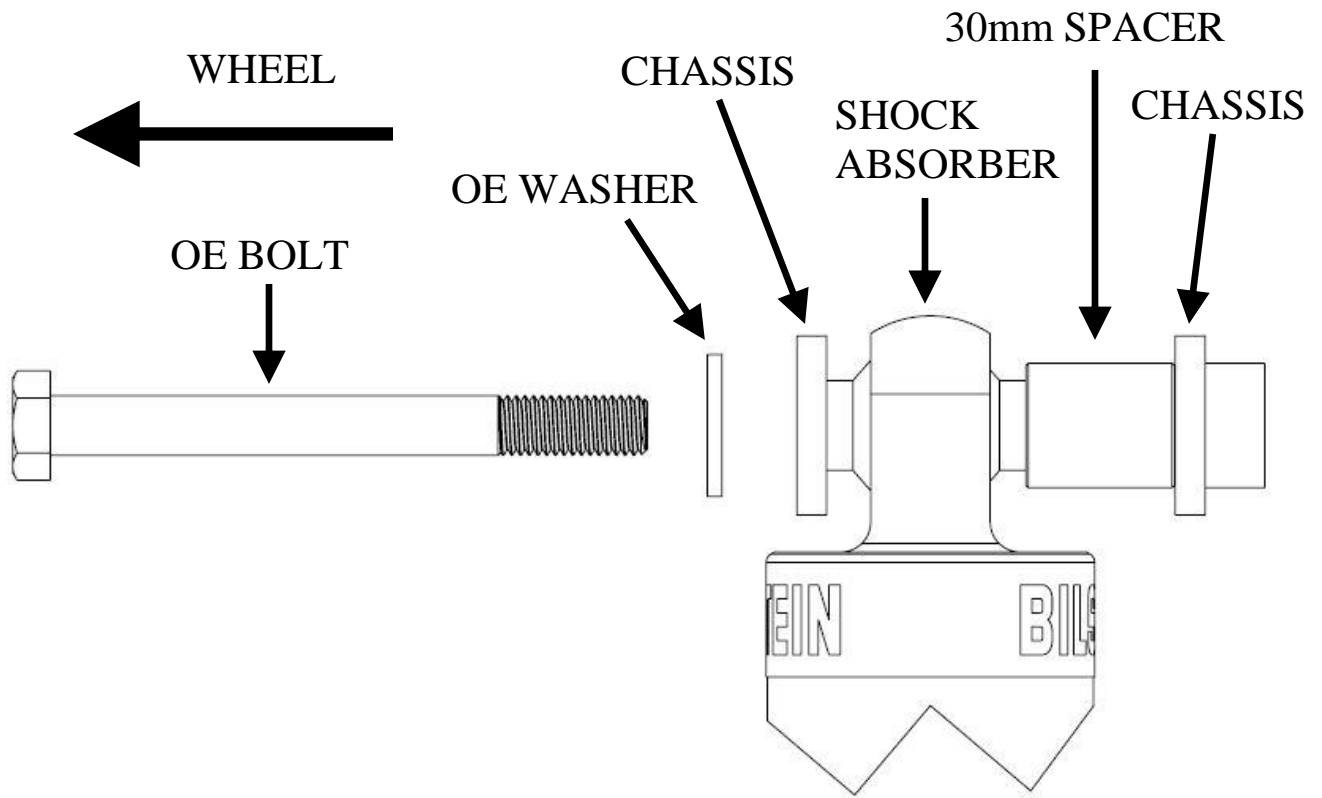

Figure 15 – Vehicle Left Side Upper Mount Assembly Diagram



Figure 16 – Vehicle Left Side Upper Mount

E4-WM5-Y631A00 MOUNTING INSTRUCTION

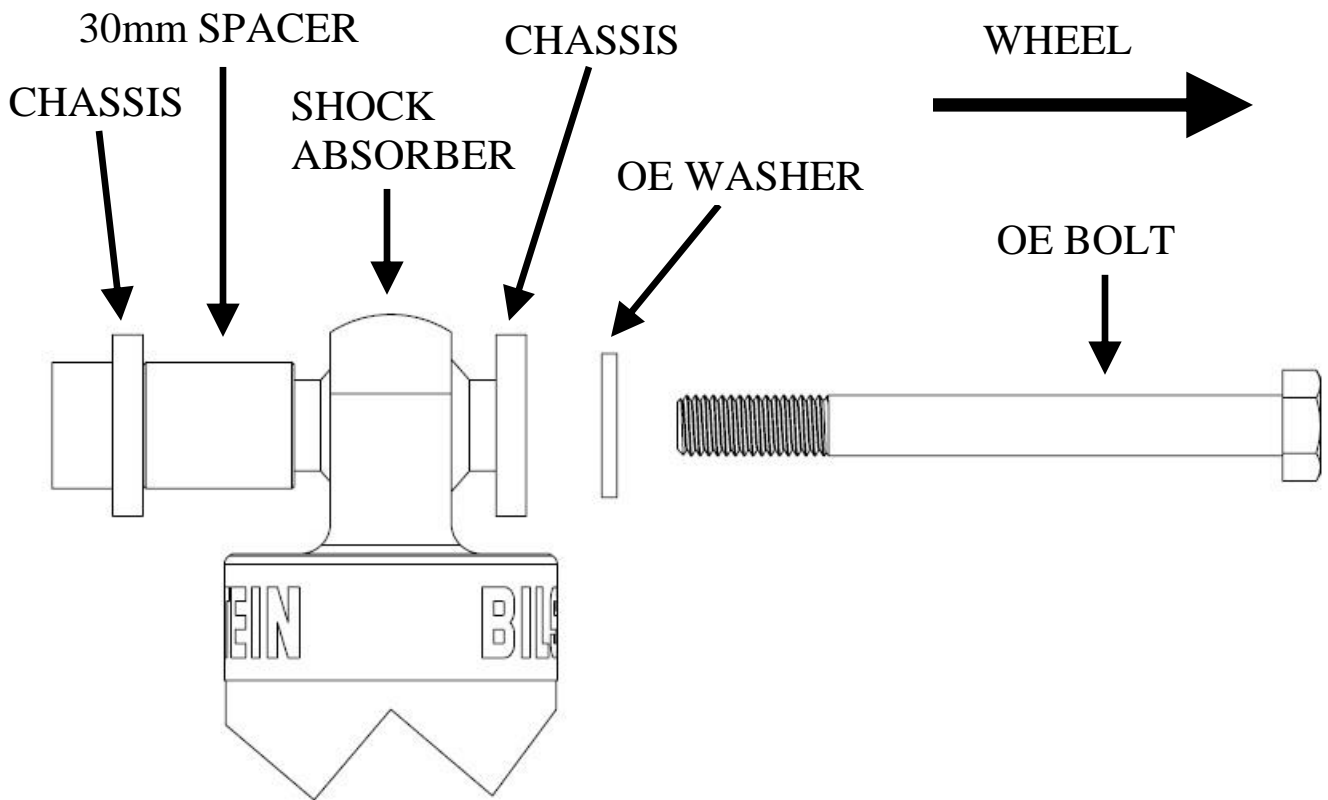

Figure 17 – Vehicle Right Side Upper Mount Assembly Diagram



Figure 18 – Vehicle Right Side Upper Mount

Shock Lower Mount Installation

- P. A mount kit is included to allow the lower shock mount to be offset away from the frame. This kit is depicted in Figure 19.

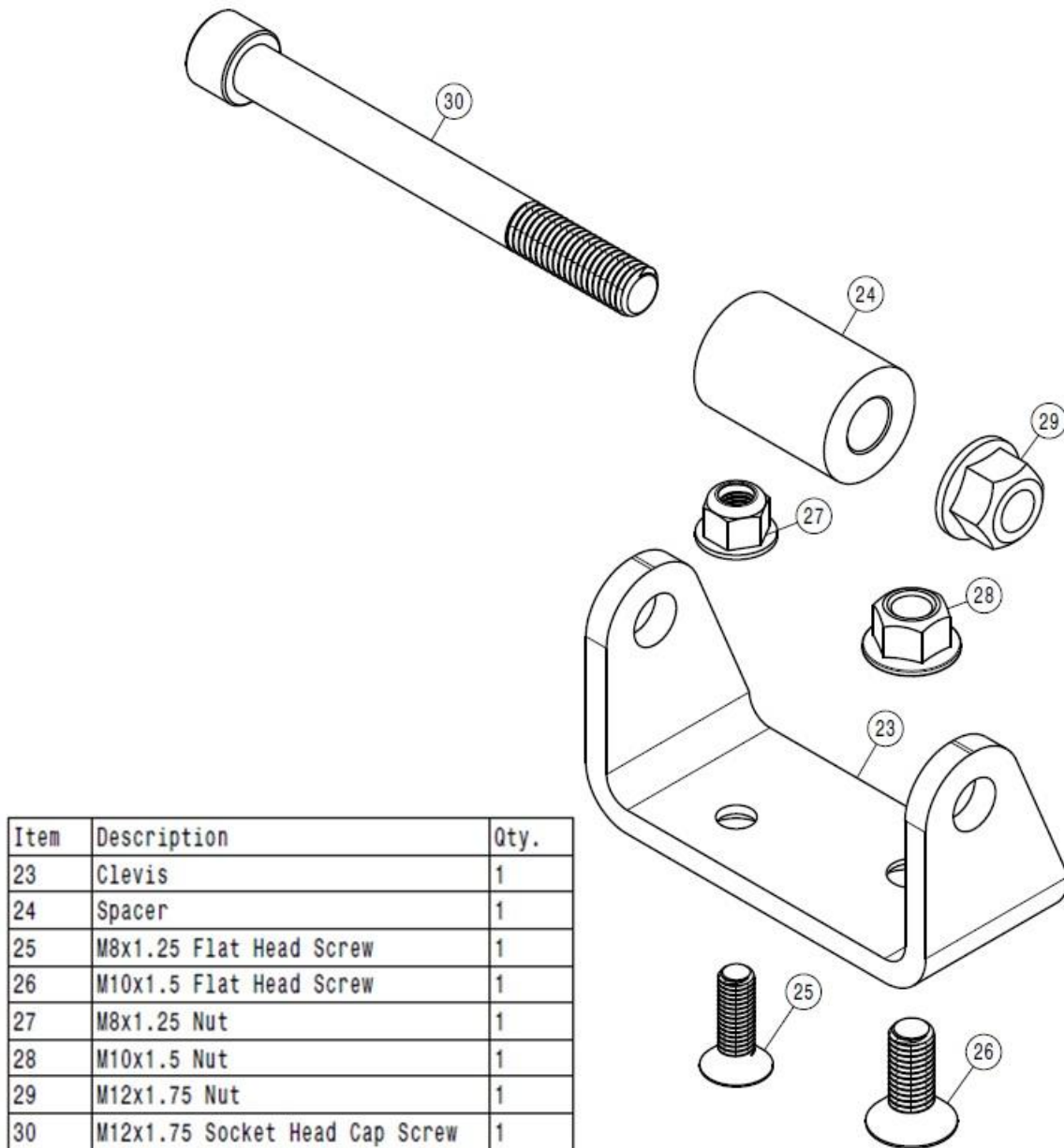

Figure 19 – Lower Mount Offset Bracket

- Q. Install the Mount Clevis (BOM item #23) using the M10x1.5 Flat Head Screw (BOM item #26) and M10x1.5 Nut (BOM Item #28) for the left side of the vehicle. For installation on the right side of the vehicle, use the M8x1.25 Flat Head Screw (BOM item #25) and M8x1.25 Nut (BOM item #27).

Torque the screw to 31 ft-lb (42 Nm).

E4-WM5-Y631A00 MOUNTING INSTRUCTION



- R. Place the Spacer (BOM item #24) between the flanges of the OE mount. Position the shock's lower mount between the outside flange of the OE mount and the clevis. Make sure the shock's lower mount is installed angling the shock toward the back of the vehicle and inward toward the chassis as shown in Figures 20 and 21. Do not tighten at this time.

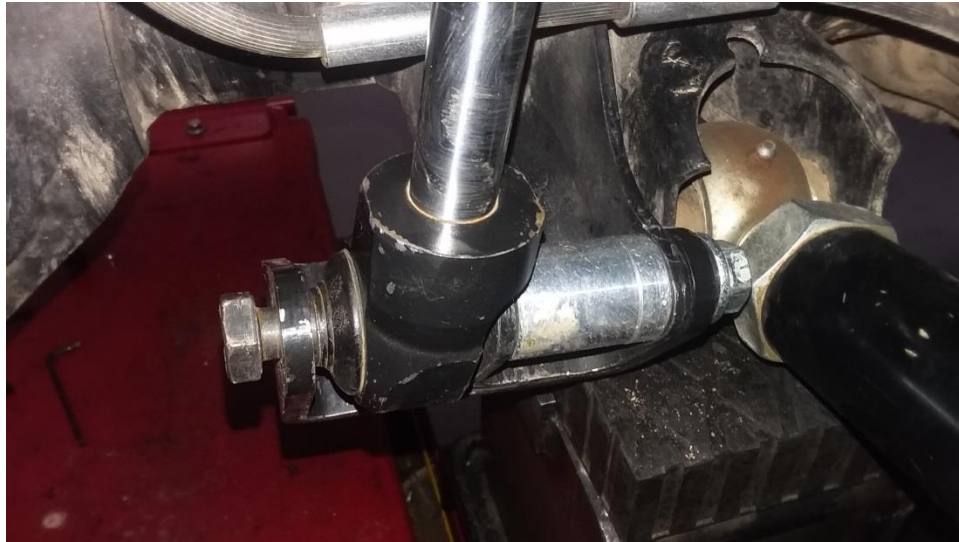

Figure 20 – Vehicle Left Side Lower Mount



Figure 21 – Vehicle Right Side Lower Mount

Reservoir Mounting

- S. Apply non-permanent thread locker to the 5/16"-18 X 1" Flange Head Cap Screw (BOM item #5) and install the reservoir mount assembly with the screw in the bottom threaded insert. Leave the screw loose for now. Rotate the assembly toward the rear of the vehicle and slide the reservoir into the clamp as shown in Figures 22 through 25.



Figure 22 - Left Front Mount Assembly Tilted



Figure 23 – Right Front Mount Assembly Tilted



Figure 24 – Left Front Reservoir Slide Into Mount



Figure 25 – Right Front Reservoir Slide Into Mount

E4-WM5-Y631A00 MOUNTING INSTRUCTION



- T. Rotate the reservoir mount assembly back to vertical. Apply non-permanent thread locker to the 1/4"-20 x 1" Flange Head Cap Screw (BOM item #4) and install it in the upper threaded insert.

Torque both screws 10 ft-lb (13.6 Nm).

- U. Position the end of the reservoir tube approximately 40mm below the bottom side of the clamp as shown in Figure 26. With the reservoir hose exiting straight toward the back of the vehicle, tighten the Socket Head Cap Screw in the Reservoir Clamp so the reservoir does not move.

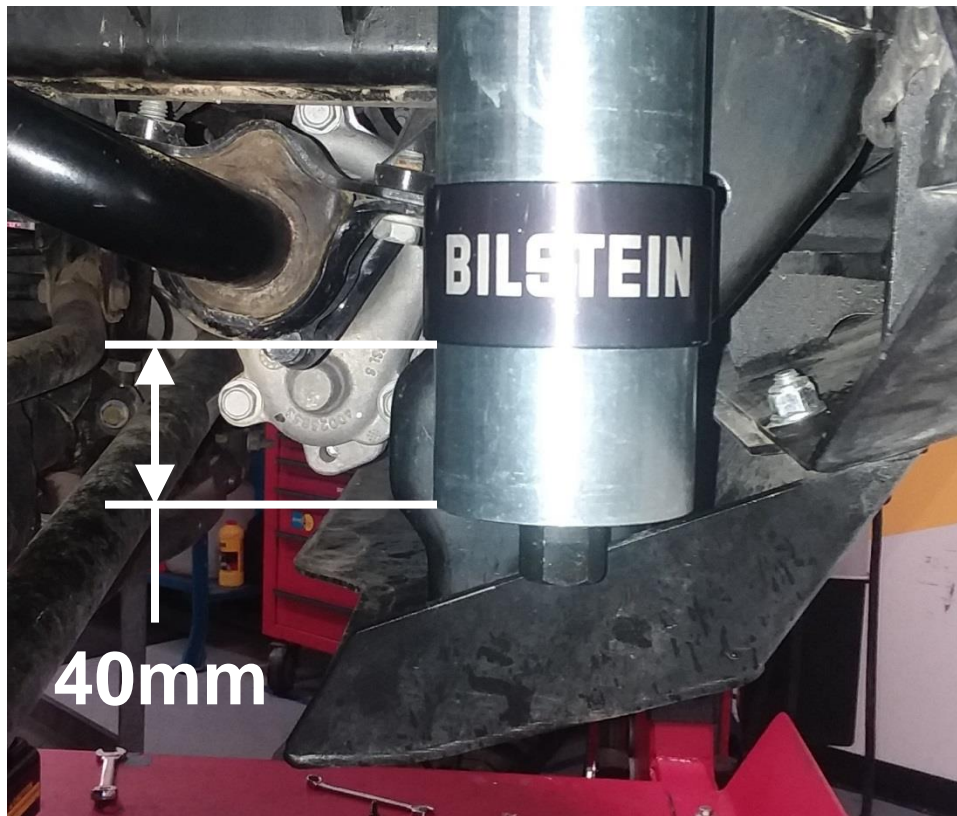

Figure 26 – Reservoir Height

Apply Rubber Protective Strip

- V. To protect the reservoir hose from abrading on the chassis, a rubber strip (BOM item #21) should be applied to the chassis body mount in the locations shown in Figure 27 on the left side of the vehicle and 28 on the right side of the vehicle. To apply the strip on the curved surface, either cut the adhesive backed side of the angled Rubber Strip (BOM item #21) to allow for flexibility around the curve, or cut it in half, and apply to either side of the curve.



Figure 27 – Left Side Location for Rubber Strip



Figure 28 – Right Side Location for Rubber Strip

Left Side Reservoir Hose Mounting

- W. Spread the Loop Clamp (BOM item #19) enough to wrap it around the left side reservoir hose. Apply non-permanent thread locker to the M8x1.25 Button head Screw (BOM item #20), and secure the Loop Clamp (BOM item #19) to the Left Reservoir Hose Mount Bracket (BOM item #16) as shown in Figures 29 and 30. The Loop Clamp (BOM item #19) should be pointed toward the front of the vehicle.

Torque the screw to 16 ft-lb (22 Nm).



Figure 29 – Left Reservoir Hose Installed

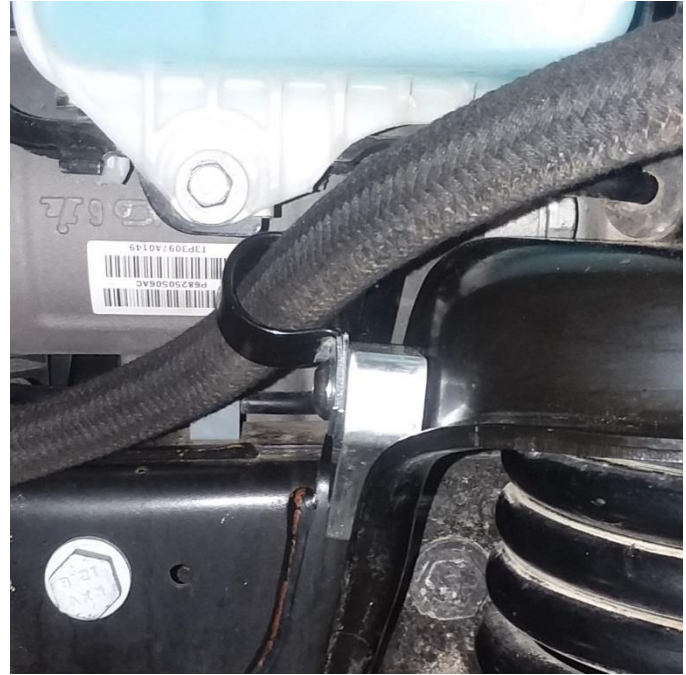

Figure 30 – Left Reservoir Hose Installed (Side View)

Right Side Reservoir Hose Mounting

- X. Spread the Loop Clamp (BOM item #19) enough to wrap it around the right side reservoir hose. Apply non-permanent thread locker to the M8x1.25 Button head Screw (BOM item #20), and using a M8x1.25 Serrated Flange Nut (BOM item #18), secure the Loop Clamp (BOM item #19) to the Reservoir Hose Mount Bracket (BOM item #22) on the right side as shown in Figure 31. The Loop Clamp (BOM item #19) should be pointing toward the outside of the vehicle.

Torque the screw to 16 ft-lb (22 Nm).



Figure 31 – Right Reservoir Hose Installed

E4-WM5-Y631A00 MOUNTING INSTRUCTION



- Y. Loosen the Socket Head Cap Screw in the Reservoir Clamp, and angle the reservoir hose toward the inside of the vehicle. Adjust the reservoir angle so that the reservoir hose is 6mm from the chassis body mount as shown in Figures 32 and 33. Make sure to maintain the 40mm distance between the end of the reservoir tube, and the bottom side of the clamp as shown in Figure 26.

Torque the Screw to 6 ft-lb (8 Nm).

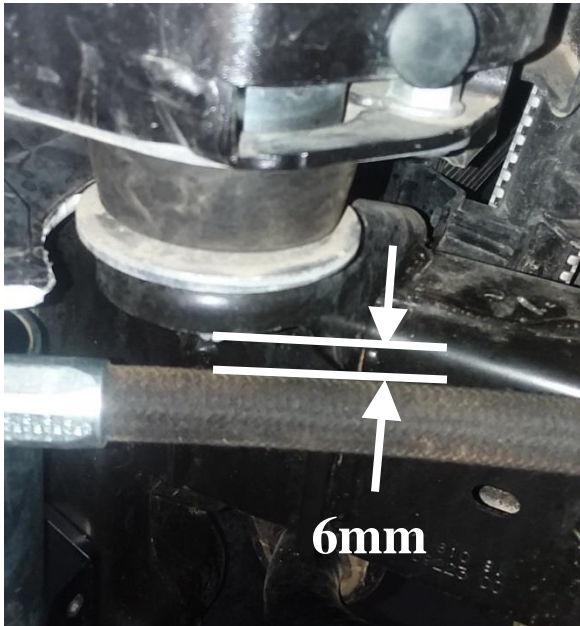

Figure 32 – Left Side Reservoir Hose Clearance

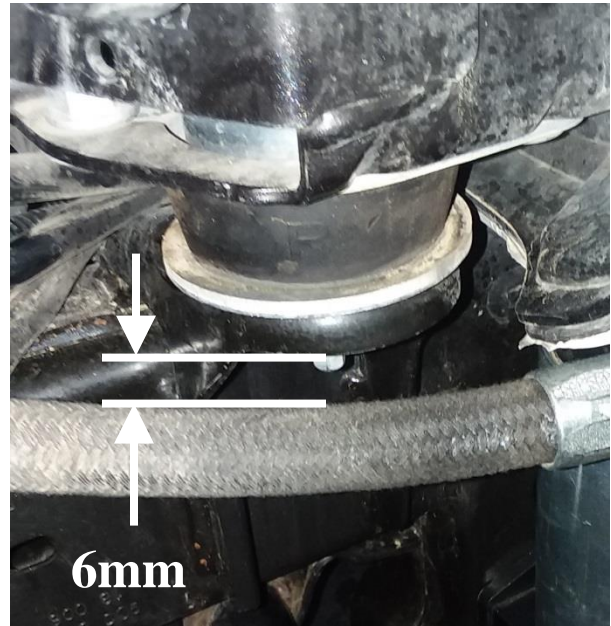

Figure 33 – Right Side Reservoir Hose Clearance

- Z. With the vehicle back on the ground, tighten the OE upper and supplied lower fasteners to the vehicle manufacture's service manual torque specifications
- AA. If the inner fender liners had been removed, reinstall them behind the reservoir hose.

E4-WM5-Y631A00 MOUNTING INSTRUCTION



Left Side Installed
(Without Inner Fender Liner)



Right Side Installed
(Without Fender Liner)

E4-WM5-Y631A00

MOUNTING INSTRUCTION



B8 8100 bypass shocks allow the user to tune the damping for the best possible ride quality of their vehicle. The shocks offer multiple zones of compression and rebound damping, depending upon the bypass configuration. The factory setting is:

Rebound – 7 full turns out from fully closed

Compression – 7 full turns out from fully closed

Note: The bypass adjusters allow adjustment up to 10 full turns out from fully closed.

B8 8100 bypass adjustment procedure:

1. Using an Allen key, hold the adjuster screw from rotating. Loosen the jam nut from the bypass adjuster housing. Back it off far enough that you can make the adjustment without the jam nut bottoming out.
2. Rotate the Allen key to make the desired adjustment.

TURN IN (Clockwise) the adjuster screw to **INCREASE** damping

TURN OUT (Counter Clockwise) the adjuster screw to **DECREASE** damping

3. Tighten the jam nut against the bypass adjuster housing while using the Allen key to hold the adjuster screw from rotating.

Make sure the bypass adjuster housing does not loosen during the adjustment process. It may be necessary to hold the bypass adjuster housing with the appropriate wrench while loosening the jam nut.

B8 8100 bypass service:

For service of your B8 8100 bypass shocks, please contact:

THYSENKRUPP BILSTEIN OF AMERICA
14102 Stowe Dr.
Poway, CA 92064, USA

Toll Free: 1-800-537-1085
bilsteinus.com