

with Installation Instructions

# Owner's Manual

## Banks Intake Resonator Delete

**2017-2019 Chevrolet 6.6L Duramax  
Turbo-Diesel Pickups**

THIS MANUAL IS FOR USE WITH KIT 48000, 48001

Gale Banks Engineering  
546 Duggan Avenue • Azusa, CA 91702  
(626) 969-9600 • Fax (626) 334-1743

Product Information & Sales: (888) 635-4565  
Customer Support: (888) 839-5600  
Installation Support: (888) 839-2700

**bankspower.com**

# General Installation Practices

Dear Customer,

If you have any questions concerning the installation of your Banks Ram-Air System, please call our Technical Service Hotline at (888) 839-2700 between 7:00 am and 4:00 pm (PT). If you have any questions relating to shipping or billing, please contact our Customer Service Department at (888) 839-5600.

Thank you.

1. For ease of installation of your Banks resonator delete system, familiarize yourself with the procedure by reading the entire manual before starting work.
2. The exploded view of the resonator delete assembly provides only general guidance. Refer to each step and section diagram in this manual for proper instruction.
3. Throughout this manual, the left side of the vehicle refers to the driver's side, and the right-side to the passenger's side.
4. Disconnect the ground cable from the battery before beginning work. If there are two batteries, disconnect both.
5. Route and tie wires and hoses a minimum of six inches away from exhaust heat, moving parts and sharp edges. Clearance of eight inches or more is recommended where possible.

6. During installation, keep the work area clean. If foreign debris is transferred to any Banks system component, clean it thoroughly before installing.

7. When raising the vehicle, support it on properly weight-rated safety stands, ramps or a commercial hoist. Follow the manufacturer's safety precautions. Take care to balance the vehicle to prevent it from slipping or falling. When using ramps, be sure the front wheels are centered squarely on the topsides; put the transmission in park; set the parking brake; and place blocks behind the rear wheels.

**⚠ CAUTION:** Do not use floor jacks to support the vehicle while working under it. Do not raise the vehicle onto concrete blocks, masonry or any other item not intended specifically for this use.

**⚠ WARNING!** Vehicles that come with a Vehicle Emissions Control Information (VECI) label affixed to the Original Equipment Manufacturer's (OEM) air intake system airbox must replace the VECI label when installing a Banks Ram-Air® Intake System. A missing VECI label will prevent the vehicle from passing a smog inspection. A replacement VECI label can be obtained from the dealership. Replacement VECI labels must be in a location that is readily visible, on a painted surface in the engine bay, and shall not be affixed to any equipment that is easily detached from the vehicle.

**Tools Required:**

- 1/4" or 3/8" drive ratchets with metric sockets
- Standard and Phillips head screwdrivers
- Clean shop towels or rags
- 8mm or 5/16" Nut Driver

**Table of Contents**

**Section 1** ..... **4**  
General Assembly

**Section 2** ..... **6**  
Stock intake tube removal

**Section 3** ..... **8**  
Banks Resonator Delete Installation

# Section 1

## General Assembly

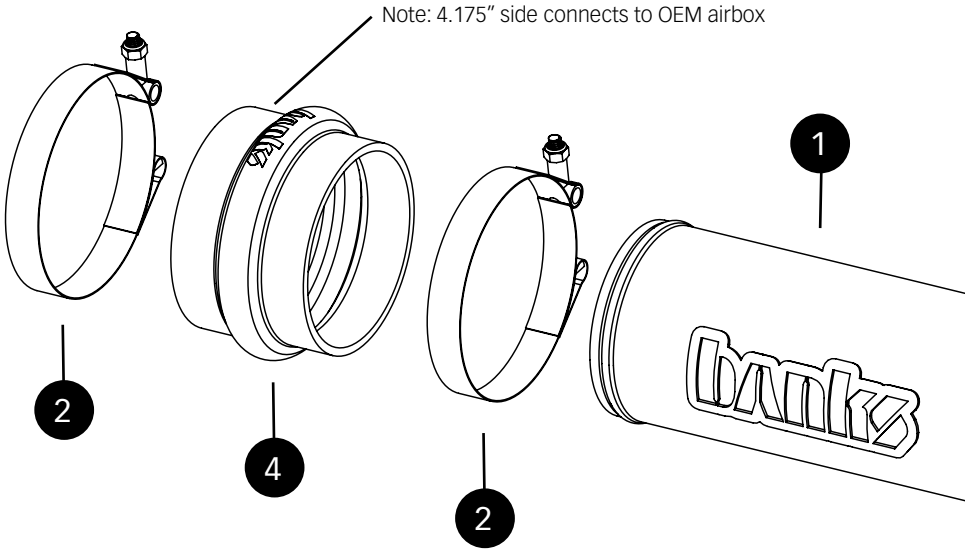

Item	Description	Part#	Qty
1	Intake Resonator Delete Tube	52661-R/N	1
2	Hose Clamp, 4"	92900	4
3	Hump Hose, 4" to 4" x 3" Long	94280	1
4	Hump Hose, 4.175" to 4" x 3" Long	94512	1

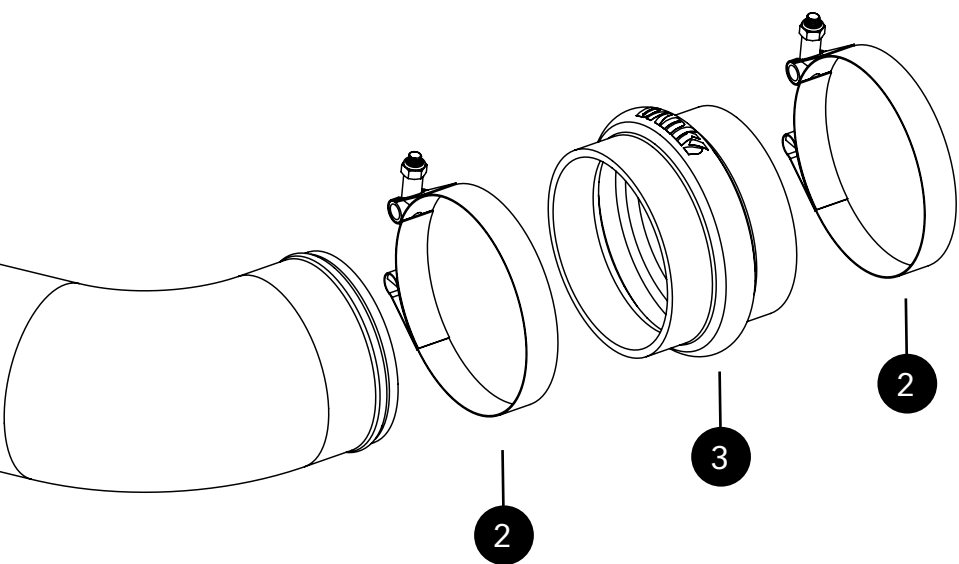

## Section 2

### STOCK INTAKE TUBE REMOVAL

Use caution when working in the engine compartment. Make sure the engine has been OFF for several hours and cool.

Some components from the stock air intake system will remain in service. Take care when removing stock air intake components to not damage them.

**Figure 1**



**1.** Using an 8mm or 5/16" nut driver loosen the clamp holding the center intake tube to the air box. Next, loosen the clamp at the opposite end of the tube connecting it to the rubber boot. Remove the center intake tube and set aside. See **Figure 1**.

**2.** To remove the resonator, loosen the small clamp connecting the resonator to the rubber boot. Remove the nut located behind the resonator, which connects it to a bracket above the engine bay. Carefully pull up and out to remove the resonator. Loosen the last clamp on the rubber boot that connects the boot to the compressor inlet tube, and remove the rubber boot. See **Figure 2, 3**

**Figure 2**



**Figure 3**



# Section 3

## BANKS RESONATOR DELETE INSTALLATION

You are about to install the Banks Intake Resonator Delete. Read and follow all steps before working on the vehicle.

Use the Bill of Materials Chart and the General Assembly Drawing to reference component nomenclature and location.

**Figure 4**

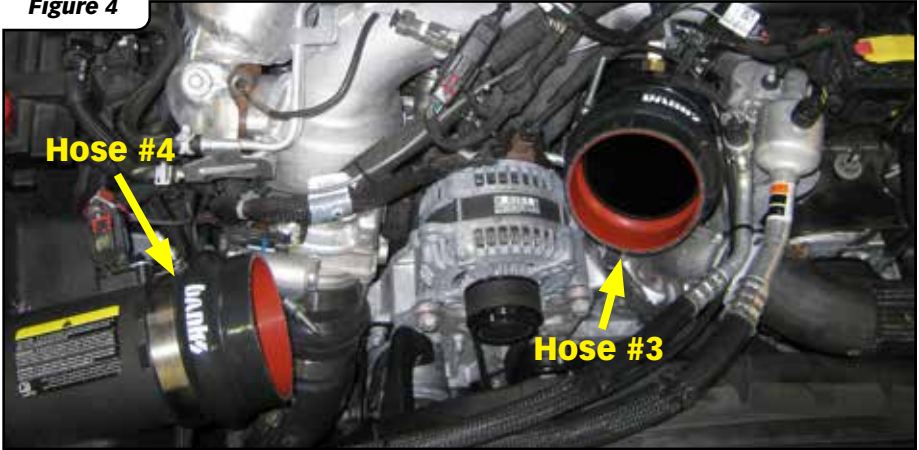

**1.** Install hose (Item #3) onto the turbo inlet pipe. Tighten clamp on turbo inlet tube. See **Figure 4**.

**2.** Install hose (Item #4) onto the OEM airbox outlet. Tighten clamp on OEM airbox outlet. See **Figure 4**.

Note: Hose #4 is identified by part number 94512. The side with the larger diameter is designed to fit over the airbox outlet.

**3.** To install the Banks resonator delete tube, temporarily slide the long end fully into hose #4 on the airbox outlet. See **Figure 5**. This will allow the short end to line up with hose #3. Then insert the resonator delete tube into hose #3 on the turbo inlet.

**4.** Adjust the alignment of the tube to line up with hoses. Each end of the tube will be inserted approximately equal lengths into hoses #3 & #4. Tighten all clamps to 5 Ft Lbs. See **Figure 6**.

**Figure 5**



**Figure 6**



Gale Banks Engineering  
546 Duggan Avenue • Azusa, CA 91702  
(626) 969-9600 • Fax (626) 334-1743

Product Information & Sales: (888) 635-4565  
Customer Support: (888) 839-5600  
Installation Support: (888) 839-2700

**[bankspower.com](http://bankspower.com)**